

FEATURES

- Dual-stacked sealed surface burners with flame recognition and automatic reignition for safety and ease of use.
- Heavy-duty stainless steel exterior with island trim.
- Individual spark ignition system—only the burner in use will spark.
- Porcelain-coated, cast iron continuous burner grates.
- Signature red, black or stainless steel control knobs (specify with range).
- Top configurations include infrared charbroiler and infrared griddle with stainless steel covers.
- Dual convection oven with two fans for even heat distribution.
- Ten cooking modes—bake, roast, broil, convection, convection bake, convection roast, convection broil and proof—bake stone and dehydration modes require accessory.
- Cobalt blue porcelain oven interior.
- Temperature probe and broiler pan.
- Wolf exclusive pivoting hidden touch control panel and coaxial oven knob.
- Three adjustable oven racks; one full-extension easy glide, one full-extension door glide and one standard.
- Self-clean, delayed start, timed cook and Sabbath features.
- Wolf exclusive spring and damper door hinge system.

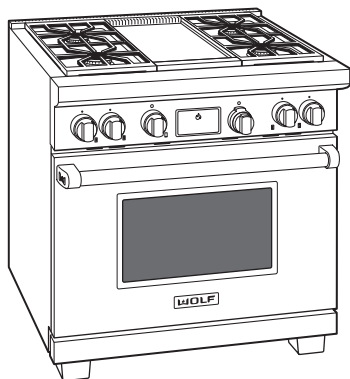

Model DF364G



MODEL OPTIONS

SIX BURNERS	DF366
FOUR BURNERS	
Charbroiler	DF364C
Griddle	DF364G

LP gas models, add (-LP).

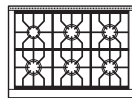

DF366

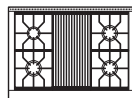

DF364C

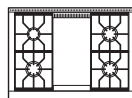

DF364G

ACCESSORIES

- 5" and 10" stainless steel risers—20" riser with shelf.
- Signature red, black or stainless steel control knobs.
- Stainless steel, brass or chrome bezels.
- Cast iron S-grates and wok grate.
- Hardwood cutting board (griddle model).
- Set of three standard oven racks.
- Full-extension easy glide oven rack.
- Temperature probe and broiler pan.
- Bake stone kit (stone, rack and peel).
- Dehydration kit (racks and door stop).
- Griddle cleaning kit (griddle model).
- Front leg and rear caster covers.
- Stainless steel kickplate.
- High altitude conversion kit—LP above 8,600' and NG above 10,250'.

Accessories available through an authorized Wolf dealer. For local dealer information, visit the find a showroom section of our website, wolfappliance.com.

SPECIFICATIONS

PRODUCT	
Dimensions	35 ⁷ / ₈ "W x 36 ⁷ / ₈ "H x 29 ¹ / ₂ "D
Door Clearance	19 ¹ / ₂ "
Weight	445-470 lb
OVEN	
Capacity	5.4 cu ft
Interior	30"W x 16 ¹ / ₂ "H x 19"D
ELECTRICAL	
Supply Service	240/208 VAC, 60 Hz 30 amp circuit
GAS	
Supply Inlet	³ / ₄ " rigid pipe 1/2" NPT female

BURNER RATING (Btu)

SURFACE	SIMMER		HIGH
	Large (5 or 3)	950	
Small	325	9,200	
FEATURE	NATURAL		LP
	Charbroiler	16,000	
Griddle	15,000	13,000	

DIMENSIONS

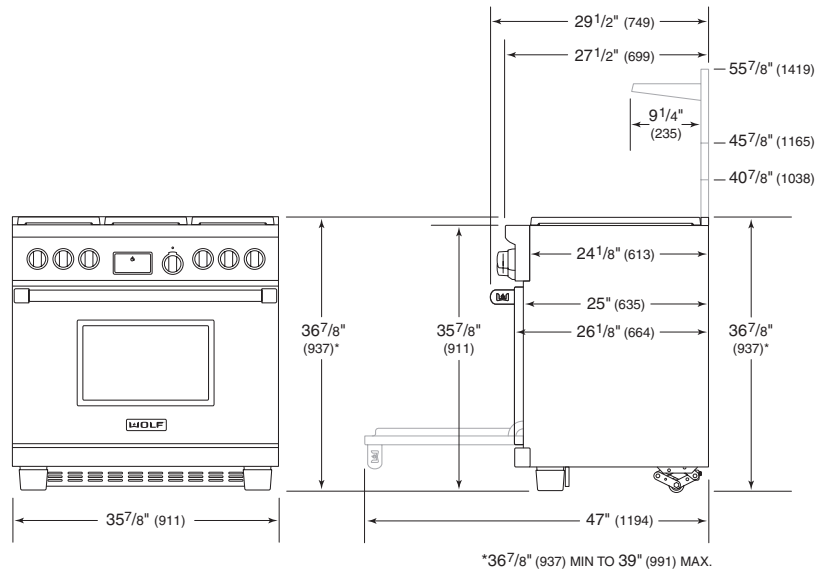

Specifications are subject to change without notice. Visit wolfappliance.com/specs for the most up-to-date information.

Dimensions may vary ±1/8" (3). Dimensions in parentheses are millimeters unless otherwise specified.

INSTALLATION

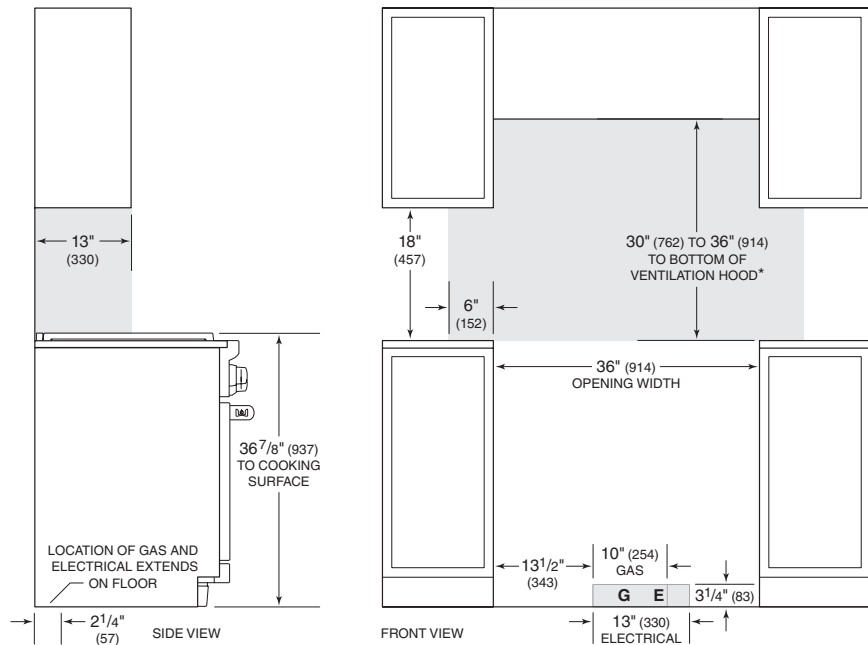

*Without ventilation hood, 36" (914) minimum clearance countertop to combustible materials, 44" (118) for charbroiler.

NOTE: Shaded area above countertop indicates minimum clearance to combustible surfaces, combustible materials cannot be located within this area.

For island installation, 12" (305) minimum clearance back of range to combustible rear wall above countertop.

A riser is required for installations against a combustible surface.